

# GLASS IS LIFE™

**O-I** makers of pure, sustainable,  
brand-building glass packaging

O-I Sales and Distribution Netherlands B.V.

Postbus 46  
3100 AA Schiedam, Netherlands  
Tel. +31 (0) 104094444

## CONTAINER & MOULD ENGINEERING EUROPE

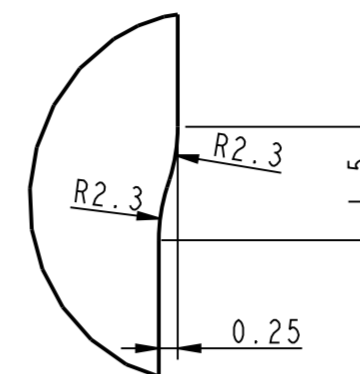

DETAIL A  
SCALE 10/1

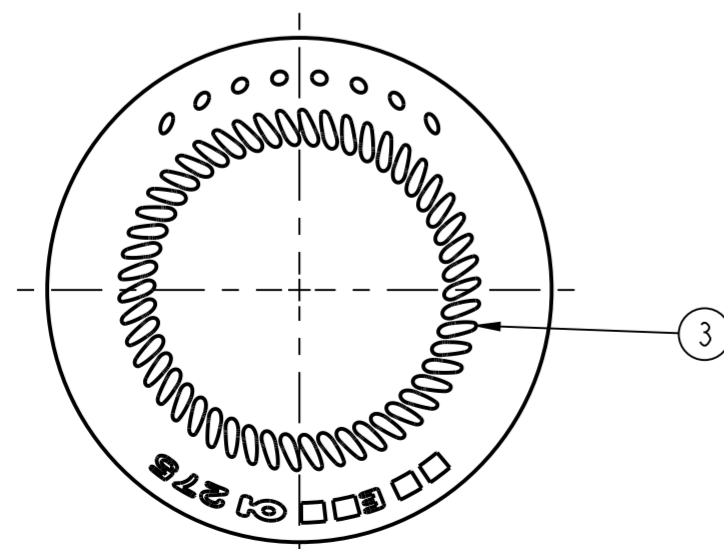
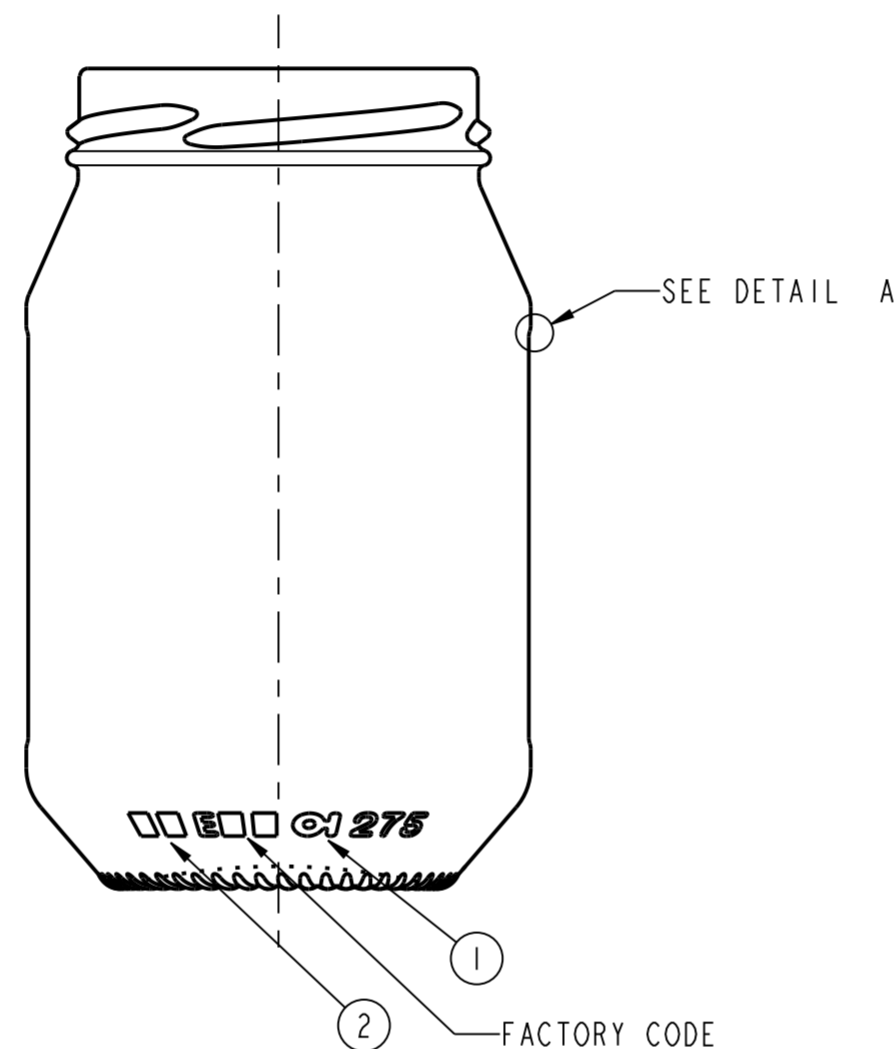
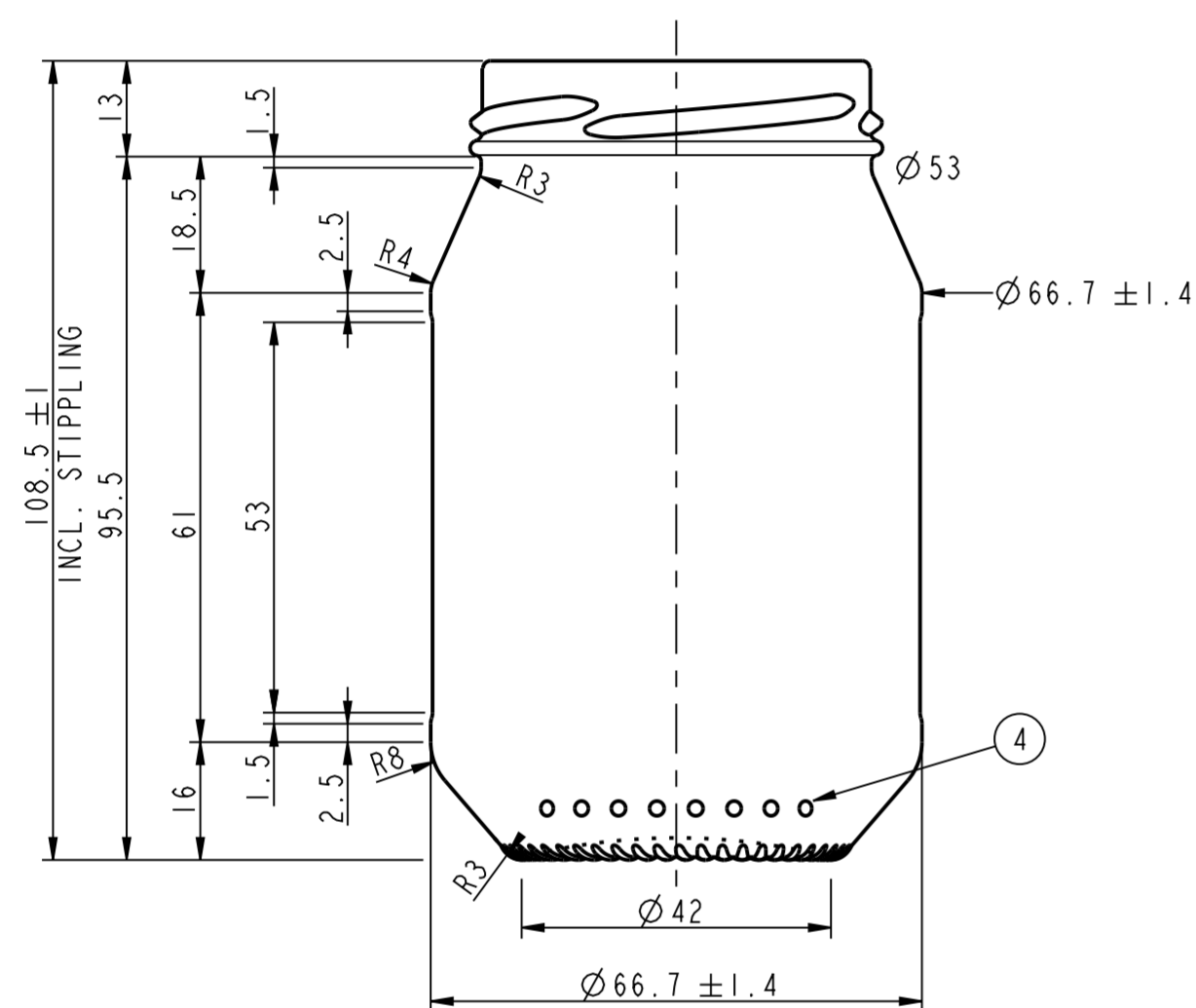

1 = TRADEMARK  
2 = CAVITY No.  
3 = STIPPLING  
THE SHAPE OF STIPPLES IS ONLY AN INDICATION AND THE CONSTRUCTION IS AT THE PRODUCTION PLANT DISCRETION.  
4 = CAVITY CODE

SCALE 1:1

NOTES:  
THIS DRAWING IS THE PROPERTY OF O-I AND MUST NOT BE REPRODUCED OR DISCLOSED WITHOUT O-I WRITTEN AUTHORIZATION.

DIMENSIONS EXPRESSED IN mm  
ONLY TOLERANCED DIMENSIONS ARE GUARANTEED.

MANUFACTURING MARKINGS SHOWN ARE FOR ILLUSTRATIVE PURPOSES ONLY, ACTUAL MARKINGS ON CONTAINER MAY DIFFER, DEPENDANT ON LOCAL LEGISLATION.



CATEGORY FOOD		TILT ANGLE 22.93°	
MAX. VERTICALITY TOLERANCE 1.5 mm		MEASURING CONTAINER NO	
FINISH SAP NUMBER 0522		FINISH REF. CETIE GME 20-04 1995	
CONTAINER OVERFLOW CAPACITY (BRIMFUL)			
275ml ± 9ml			
CONTAINER WEIGHT			
138g APPROX.			
FINISH DESIGNATION NL_58_GME 20-04_H130_0522			
PROCESS P&B	RETURNABLE NO	DESIGN REF.	

275 ml jar

DESIGNER SK DATE 17/06/14

CHECKED DATE

DRAWING NUMBER 140493  
MOULD/SAP NUMBER 003142

No	DATE	REVISIONS	DESIGN/CHECK
DRAWING UPDATE OLD DESIGN NR. 027.2326			