

COLOUR	SAP SPEAKING NO	SAP MATERIAL NO
WHITE FLINT	30-13020 -0	31003020

Bottom view

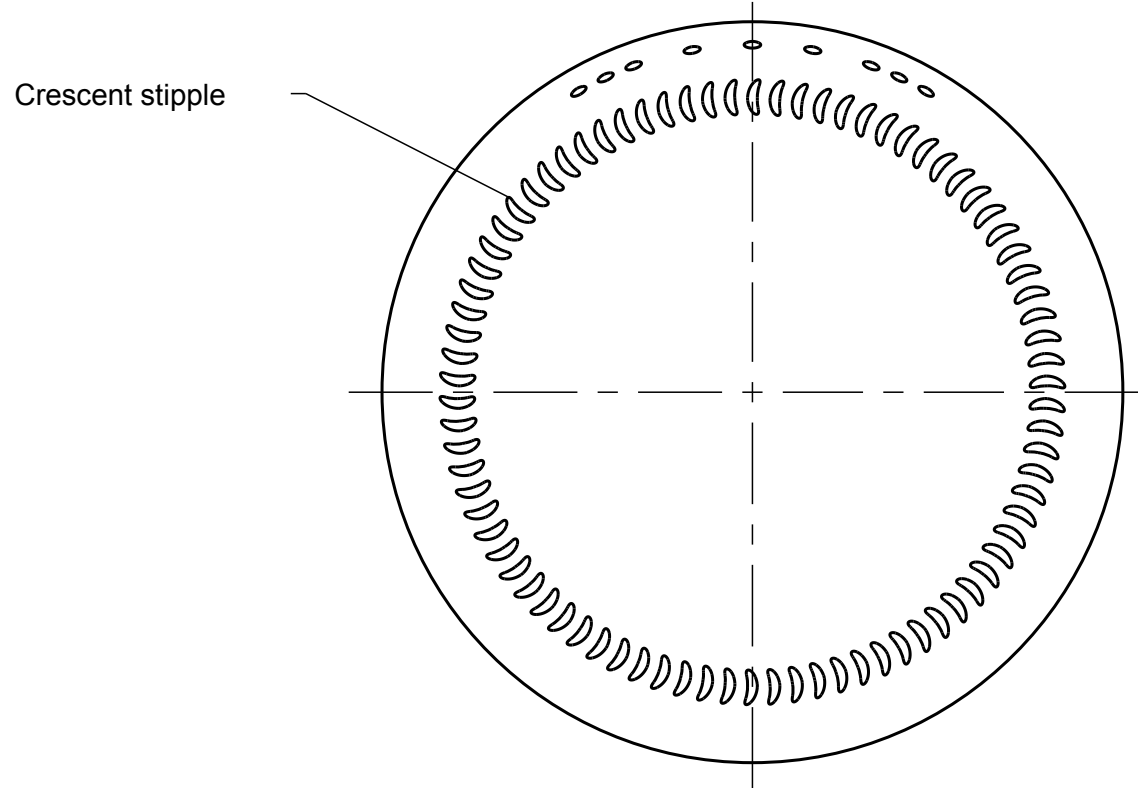

Front view

TO 82

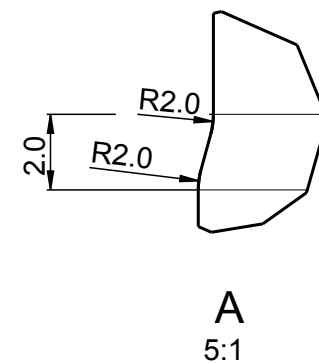
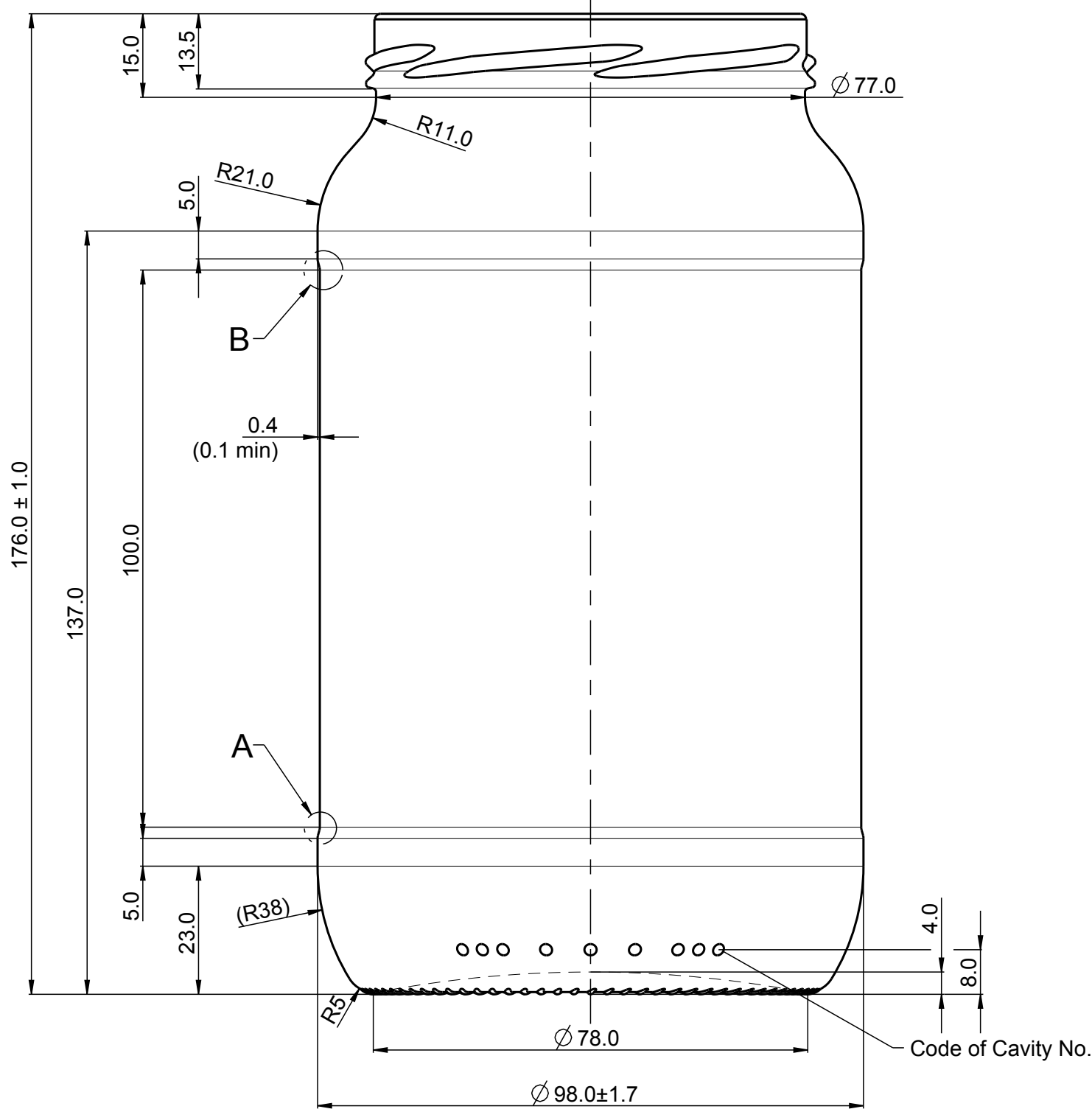

A  
5:1

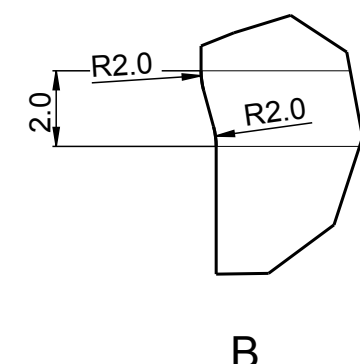

B  
5:1

Back view

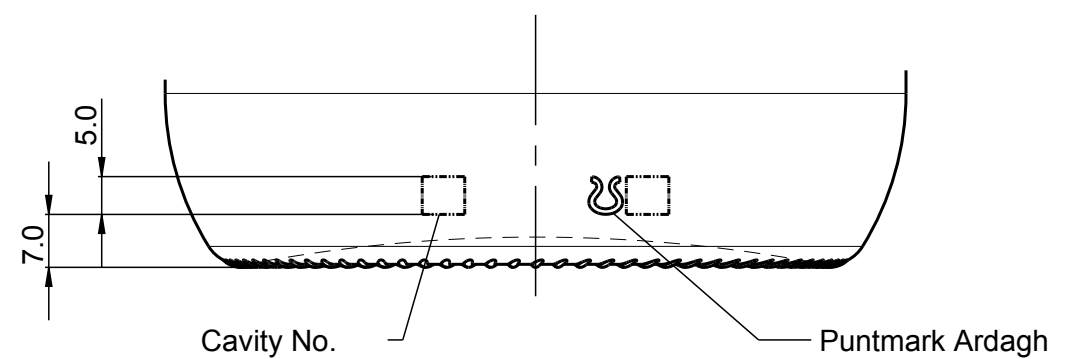

0.4 STIPPLE HEIGHT IS INCLUDED IN ALL DIMENSIONS FROM THE BASE

Nenninhalt NOMINAL CAPACITY		SPECIFICATION AGREEMENTS ARE BASED ON TOLERANCED DIMENSIONS ONLY DO NOT SCALE DRAWING COPYRIGHT RESERVED, NOT TO BE COPIED IN WHOLE OR PART WITHOUT WRITTEN PERMISSION FROM ARDAGH GLASS LTD. ALL DIMENSIONS ARE IN MILLIMETERS Document supervised by SAP, cProject and Windchill PDMLink systems) Allgemeintoleranzen vollautomatisch gefertigter Flaschen gemäß DIN 6129				Product & Mould Design  Glass - Europe	ArdaghGroup 		
Randvollinhalt BRIMFULL CAPACITY	1062.0 ml ± 16.0 ml								
Kopfraum VACUITY	-					Gezeichnet DESIGNER	ChemnitzK	Blatt SHEET	1 / 1
Mündungsbezeichnung FINISH DESCRIPTION	TO 82					Datum DATE	09.01.2013	Maßstab SCALE	1:1 (A2)
Mündungsnummer FINISH NUMBER	AF04101					Kunde CUSTOMER		Projekt PROJECT	6132
Bohrungsdurchmesser min MINIMUM THROUGH BORE	-					Produkt Name / PRODUCT NAME Jar STD03_1062_C30_82TO			
Gewicht WEIGHT NOMINAL	~380 g					Alte Nummer. OLD NUMBER			
Verwendung USAGE	NON RETURNABLE					Zeichnungs Nr./DRAWING No.			
Druck CARBONATION	-	B Add SAP Material Number	ChemnitzK	-	06.02.2013	Produkt Code / PRODUCT Code		13020 -0	
Kippwinkel TILT ANGLE	~28°	A First drawing	ChemnitzK	-	09.01.2013	D 13328 B			
		Änderung / REVISION		Erstellt/DSG	Geprüft/CHK	Datum / DATE			